

- 1a Downstroke coil 45W (direct connection to the solenoid valve)
- (1b) Downstroke coil 48/12 V cc 36 W (direct connection to the solenoid valve) >>
- 6 High speed coil 45W
- M Terminal board
- (H) Oil heater resistance 70W (without thermostat)
- (S) Motorprotector
- (T) Oil thermostat 70°C opening

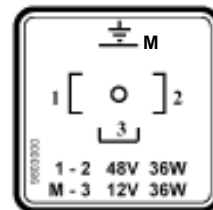

### MOTORCONNECTION

Connect the line input in accordance with the original motor terminal board configuration :

#### SINGLE PHASE

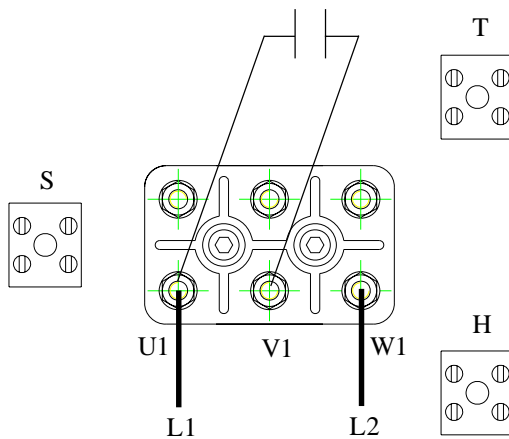

#### THREE PHASE

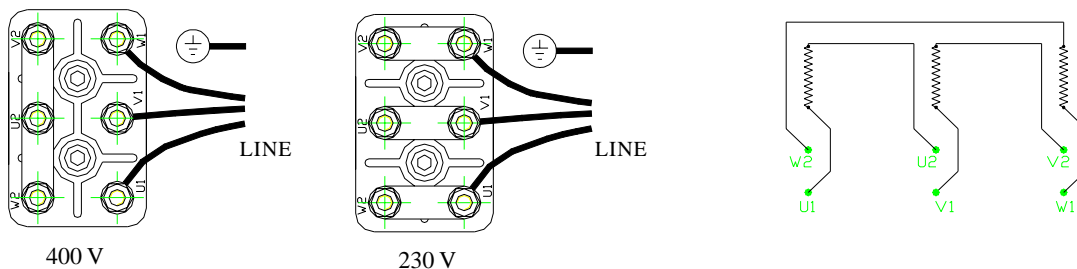

**ELECTRICAL CONNECTION  
PUMP UNIT  
03/E**



**Start Elevator**

**06 430 / G**

**rev. 1**

**1/1**